

# BASICS OF ASPHALT PAVING: SCREEDS

Kevin Jeske – Great Lakes Regional Manager



ASTEC INDUSTRIES, INC.



# CONSTRUCTING QUALITY PAVEMENTS

Whether its new construction or rehabilitation, these key steps are necessary to ensure a good asphalt pavement:

1. Good Planning
2. Communication
3. Proper Mix Production
4. Delivery
5. Correct Placement Techniques
6. Density

## Important to Remember:

- Uniform Head of Material
- Set Proper Angle of Attack
- Maintain Constant Paver Speed



# HOW FAR WE'VE COME



1934



1970's



1990's



2018



ASTEC INDUSTRIES, INC.





# IT'S ALL ABOUT BALANCE

To build high quality, smooth riding roads, the paving speed **MUST** be at a constant rate.

Remember: Consistency wins every time!

## Top Quality Paving Techniques

1. Uniform Head of Material
2. Proper Angle of Attack
3. Constant Speed of Paver



# UNDERSTANDING THE PAVER

The two components of an asphalt paver are:

- **The Tractor:** The tractor pushes the trucks and tows the screed
- **The Screed:** The screed slopes and lays the desired depth needed per job spec.

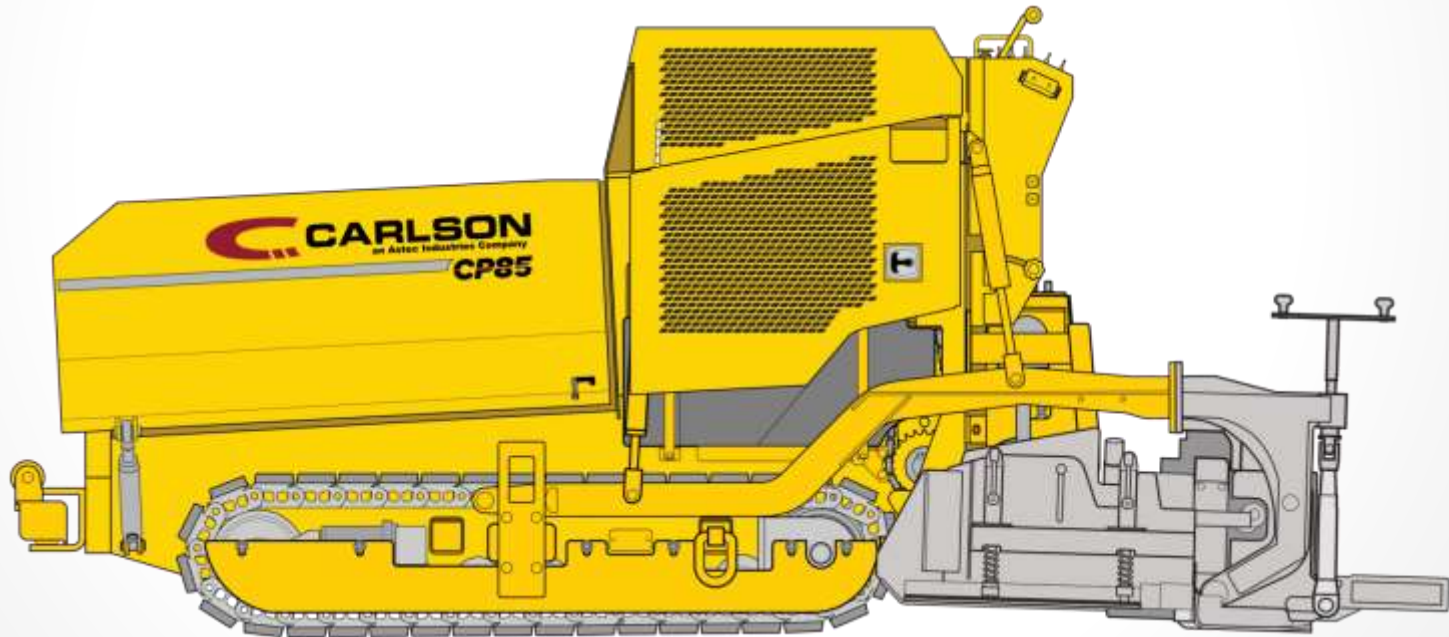

# TARGET LINE/LINE OF PULL

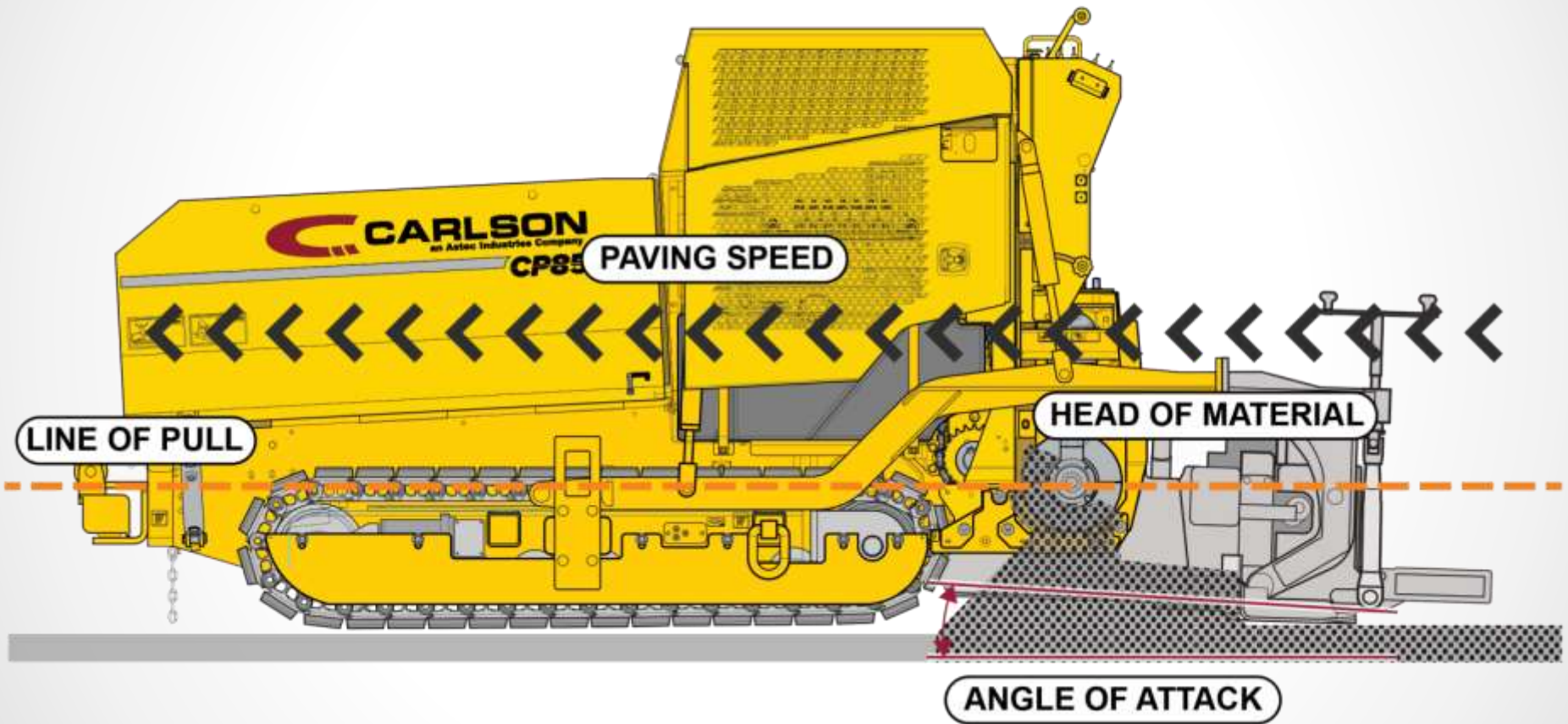

# TARGET LINE/LINE OF PULL

With a high tow-point and a thin lift, you would have a line of pull that is always pulling upward.

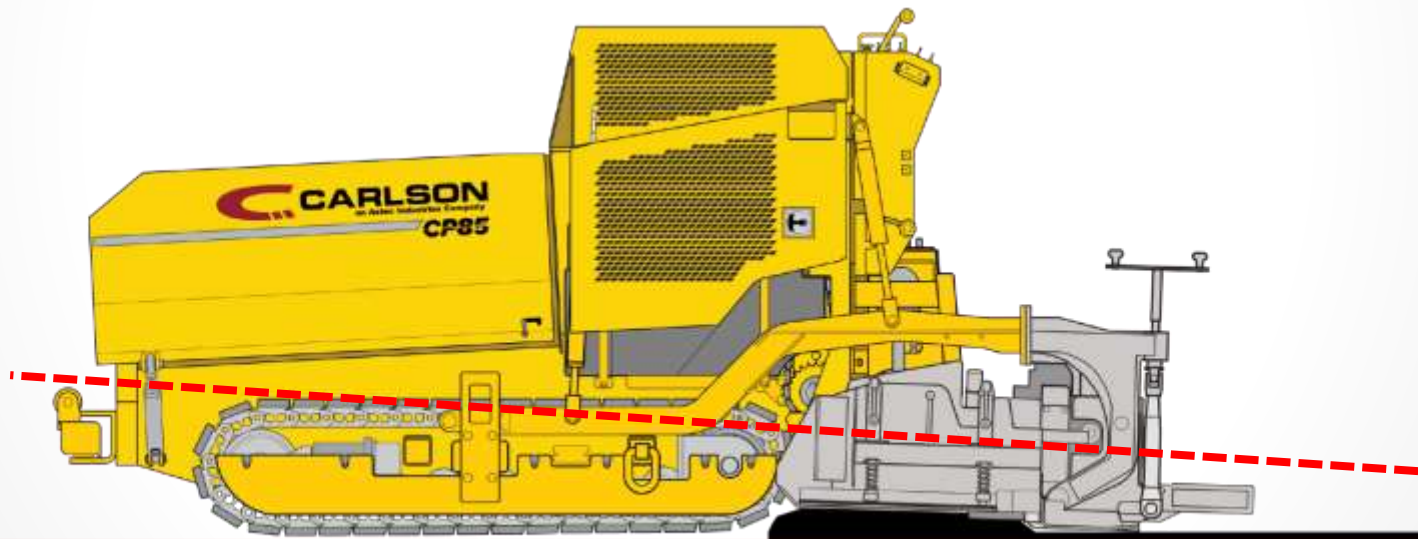



# TARGET LINE/LINE OF PULL

With a low tow-point and a thick lift, you would have a line of pull that is always pulling downward

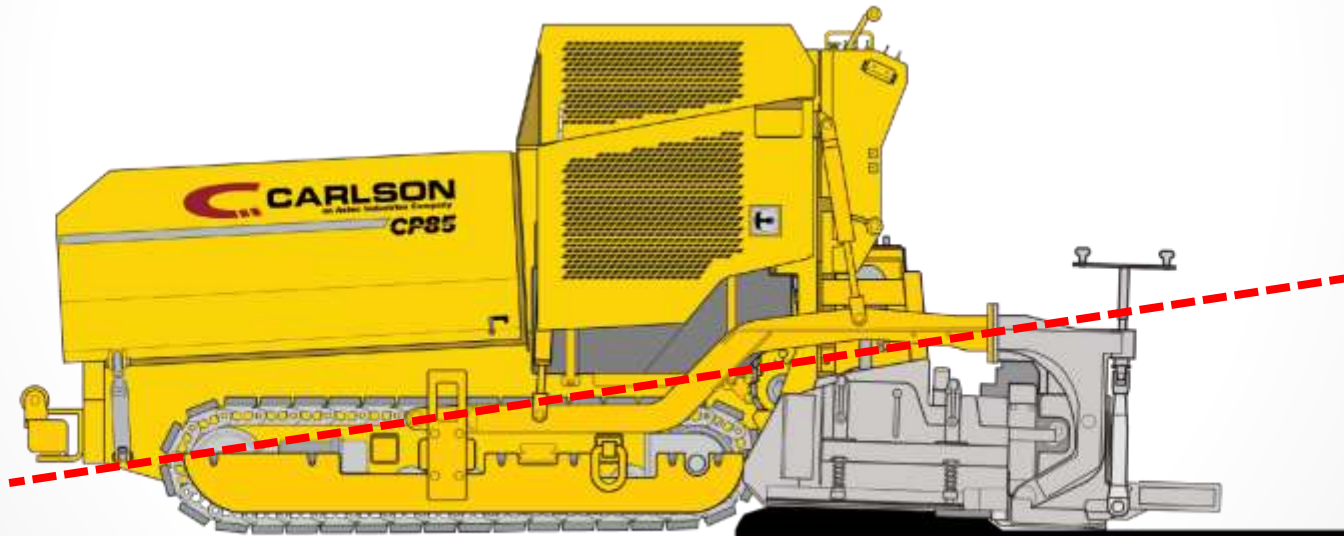



# TARGET LINE/LINE OF PULL

Place the tow-point 1 inch higher than the loose mat thickness you are laying.

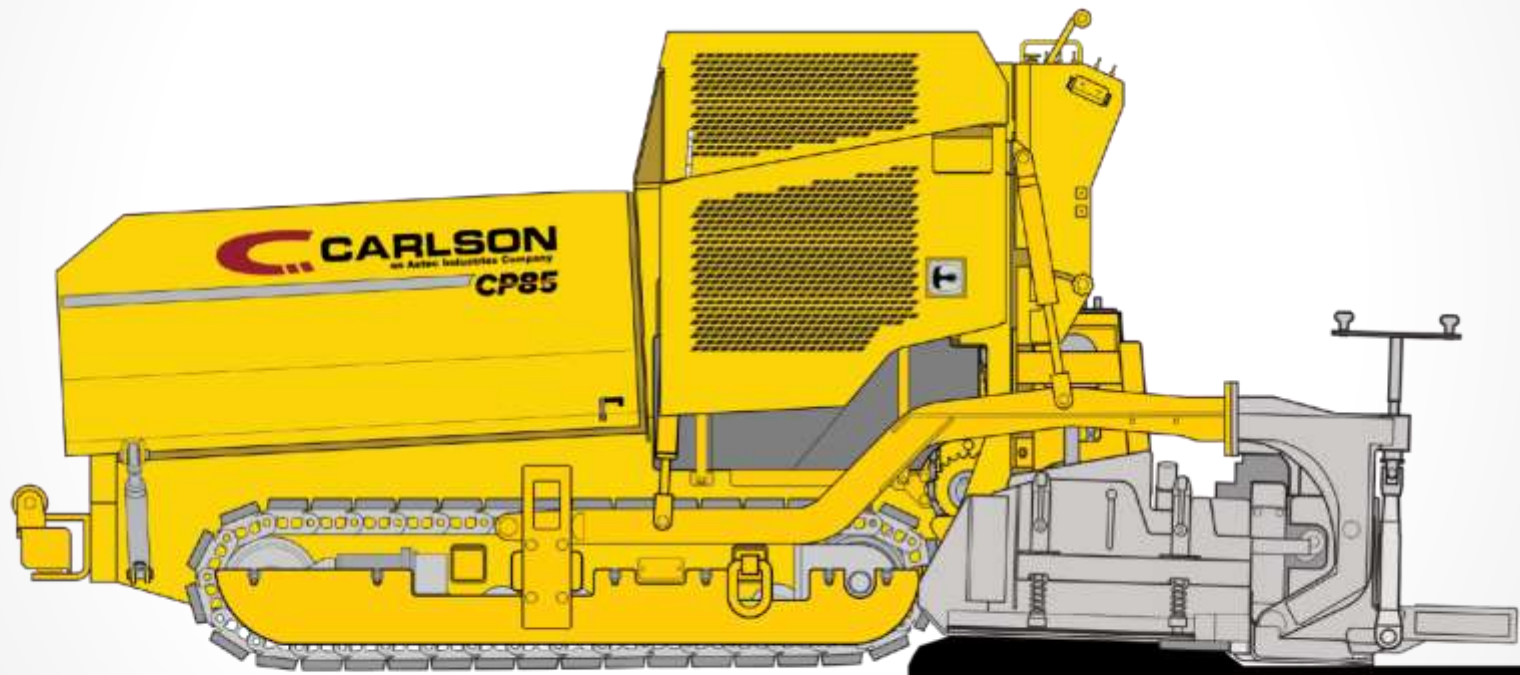

# 4 WAYS TO CONTROL THE SCREED

1. Manual with depth screws
2. Grade control and manual
3. Dual grade control
4. Grade and slope control

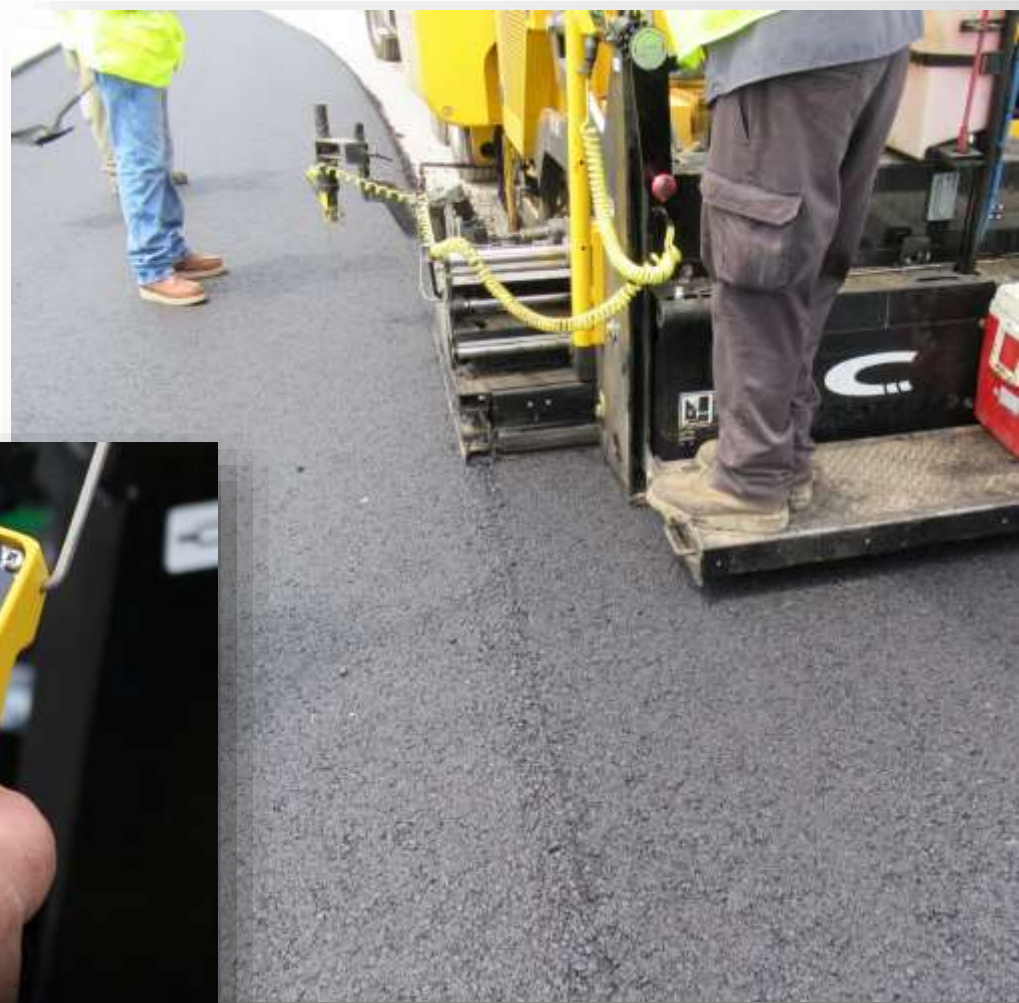

# SCREED REACTION TIME

For a screed to rebalance, it takes 5 to 6 tow arm lengths for the screed to rebalance the forces working against it.

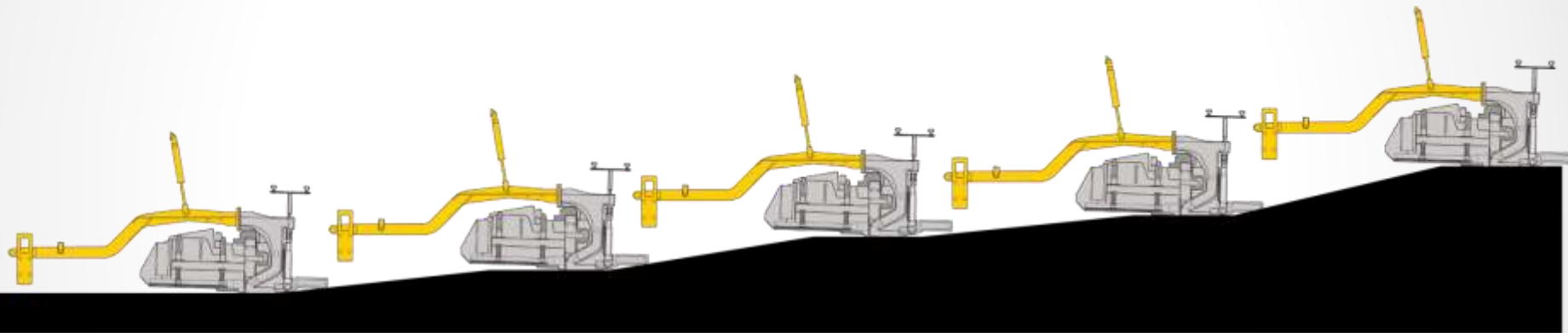

Remaining 30% to 35%

60% to 65%



ASTEC INDUSTRIES, INC.



# CORRECTION TIME OF THE SCREED

This theory applies to running the screed manually and in automatic.

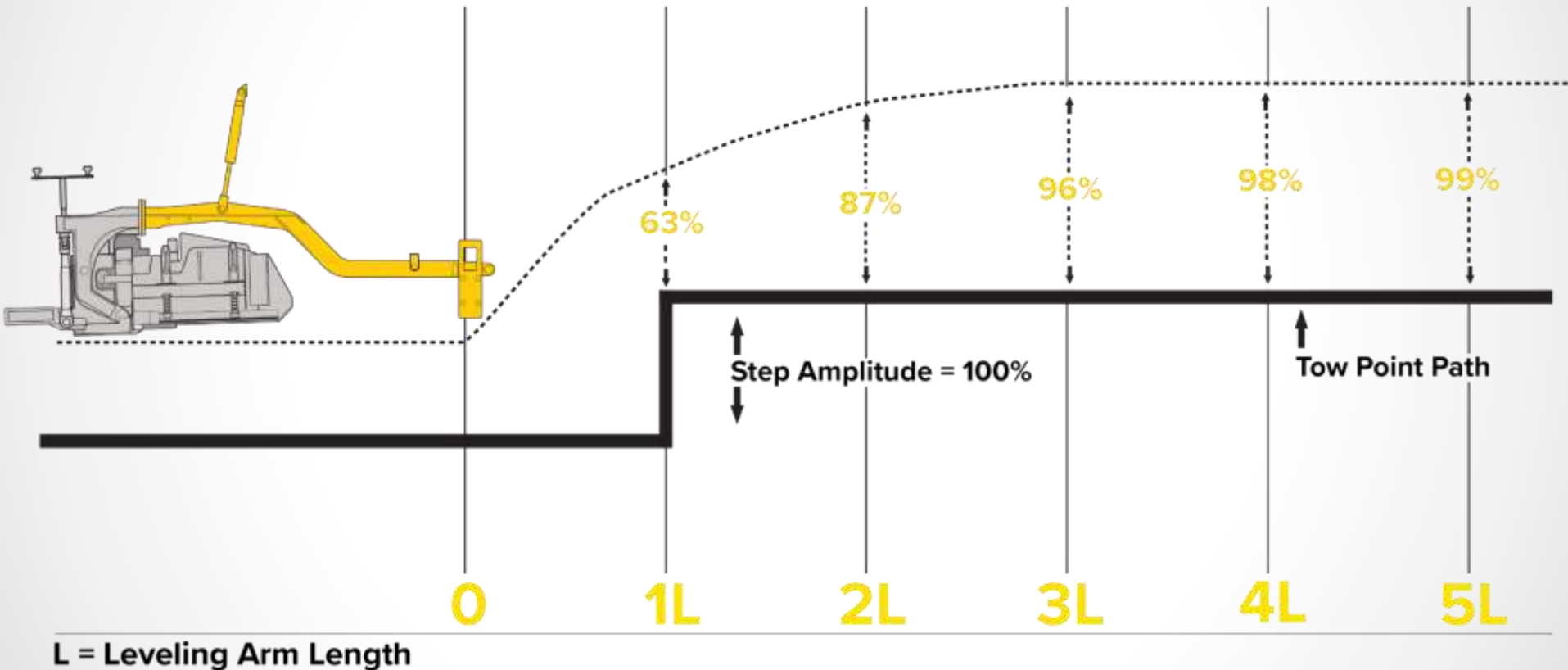



# PREPARING FOR THE JOB

The paver size needs to be matched to the production rates and job conditions. Not everybody has a fleet of pavers to choose from and you may get what you get

If you have a job that is 10' wide then use an 8' paver when possible

If you open an 8 footer up to 10 feet, your operation will more than likely benefit

**Note:** no paver likes to run closed up and no crew likes to run one that way.



# EXISTING GRADE CONDITIONS

**(HMA Design)**

**Mix design**

Latex  
Tender  
Coarse

The MS-2 says, “The minimum thickness for a surface mix usually varies from 2-3 times the maximum aggregate size

**If you see a difference in the mat quality or shadows that just appear, it is usually a mix problem**

**Different mixes have great effect on screed performance and overall mat quality**

**With different mixes, it is possible that prestrike-offs and angle of attack on the screeds will need adjusting. This will be discussed later.**



# EXISTING GRADE CONDITIONS

Existing grade conditions can cause texture stripping to occur. The primary reason for this is material thickness.

Texture strips should not be confused with segregation.



# EXISTING GRADE CONDITIONS

Grade should be checked for high spots that exceed one-third of the intended mat thickness.

If these problems exist, they should be removed prior to the start of paving.

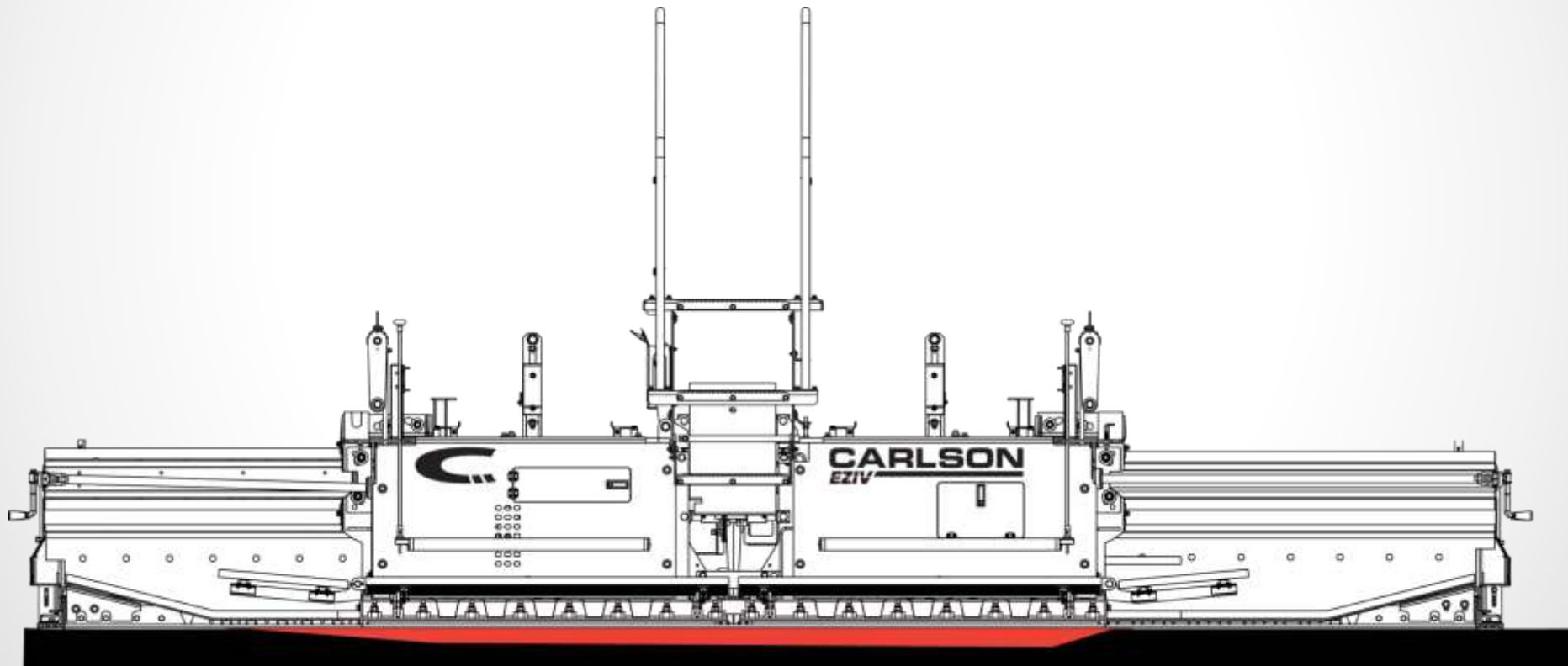

ASTEC INDUSTRIES, INC.





# SCREED BASICS AND SETUP



ASTEC INDUSTRIES, INC.



# CHECKING THE CROWN

Think of how much material you would use with 1/8" over 12' multiplied by 3000'

Pull: 3,000 feet

Crown: 1/8 inch average

Width: 12 feet

Cost per ton: \$85.00

\$2,390.00

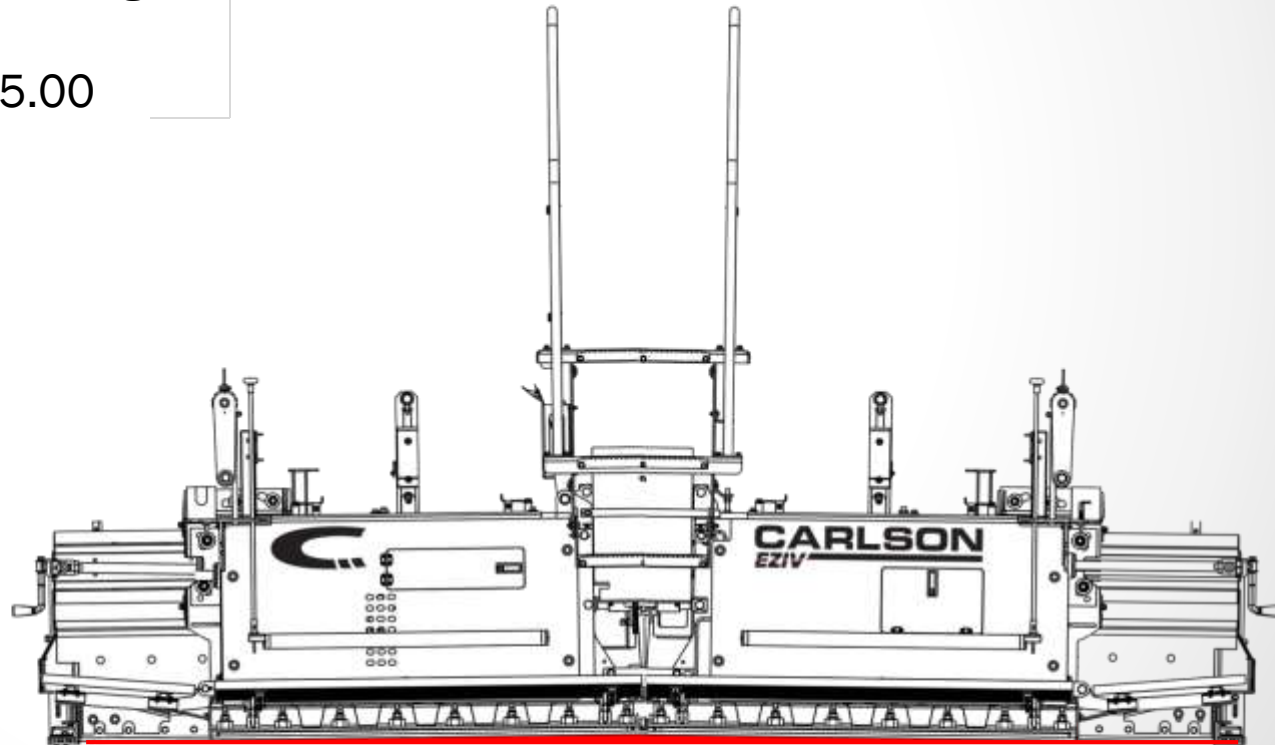

# CHECK SLOPE IN THE EXTENSION

When you finish at one end of the job and start at another spot, is it possible that someone could have bumped the switches on the move?

If you didn't touch the screed and moved back and restarted, you would just be low on the joint and adjust the thickness.

How many would have caught this quick?

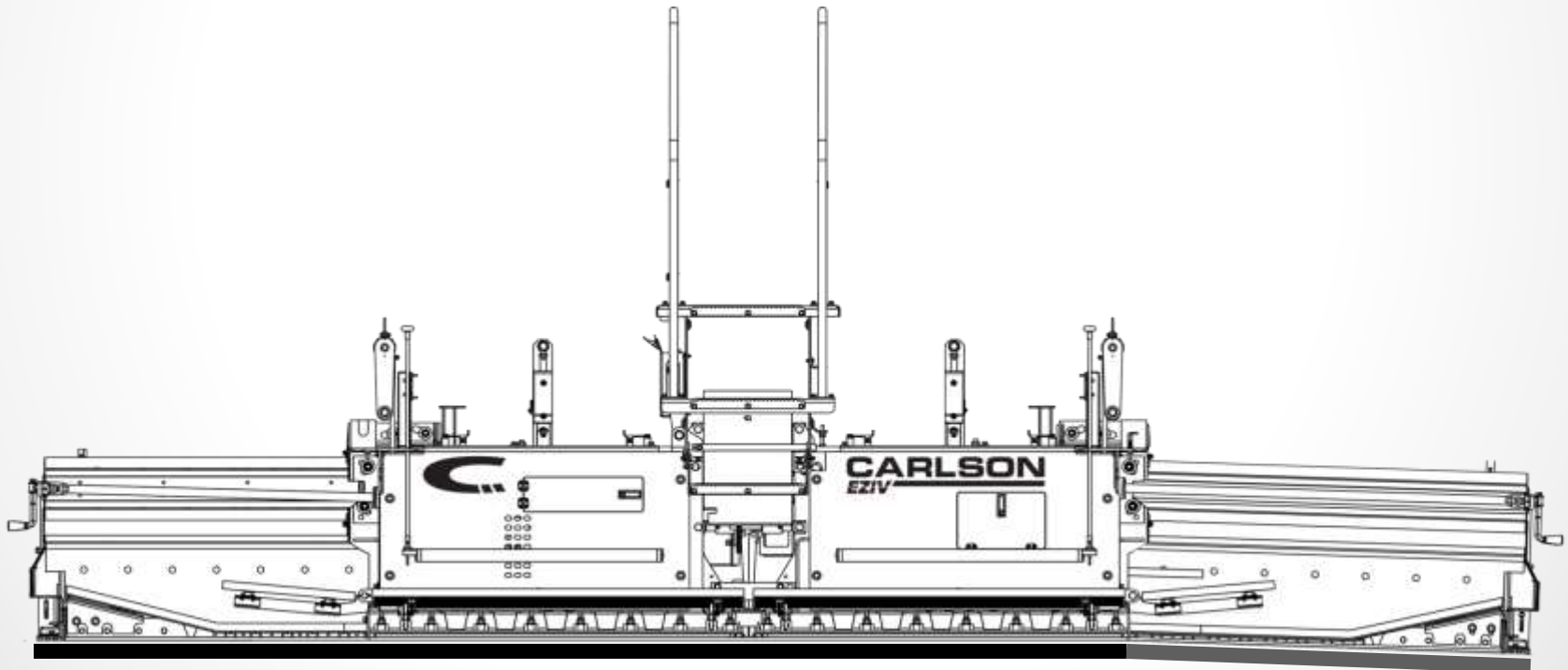

# STRINGING THE SCREED

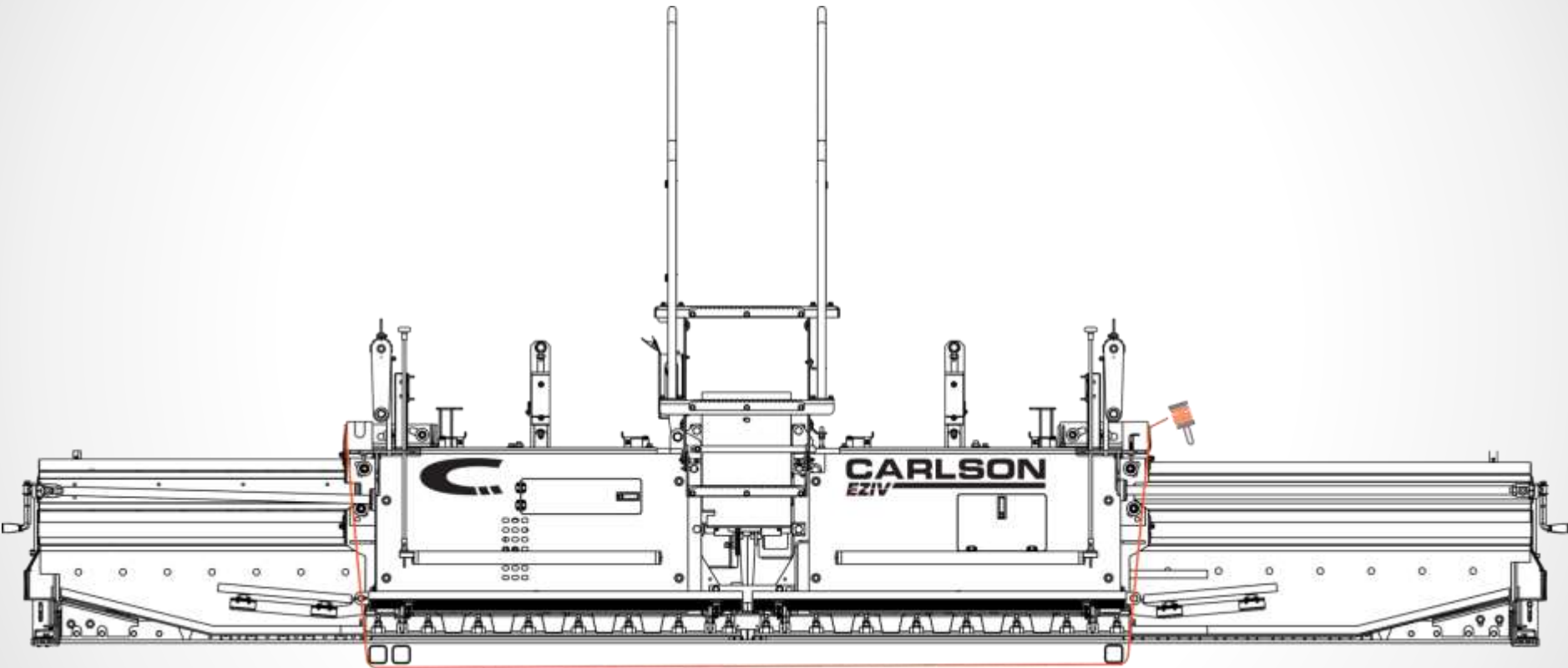

ASTEC INDUSTRIES, INC.





# LEAD CROWN

There is more to checking the screed than just at the tail. Your lead crown is very important

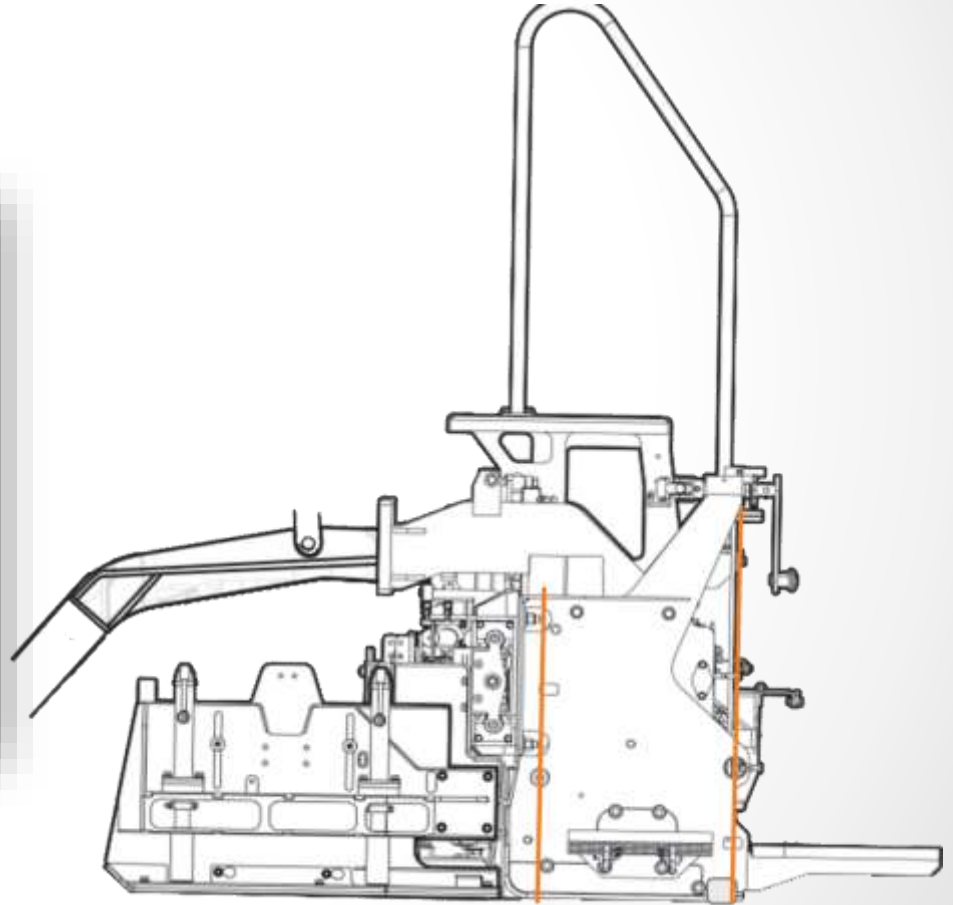

# ANGLE OF ATTACK

In order for a screed to produce a mat that is consistent in density and texture, the pressure exerted by the rear of the screed plate must be equal along the entire plate

- A normal angle of attack is set on the rear extension to 3/16 inch
- A normal angle of attack is set on the front extension to 3/16 inch

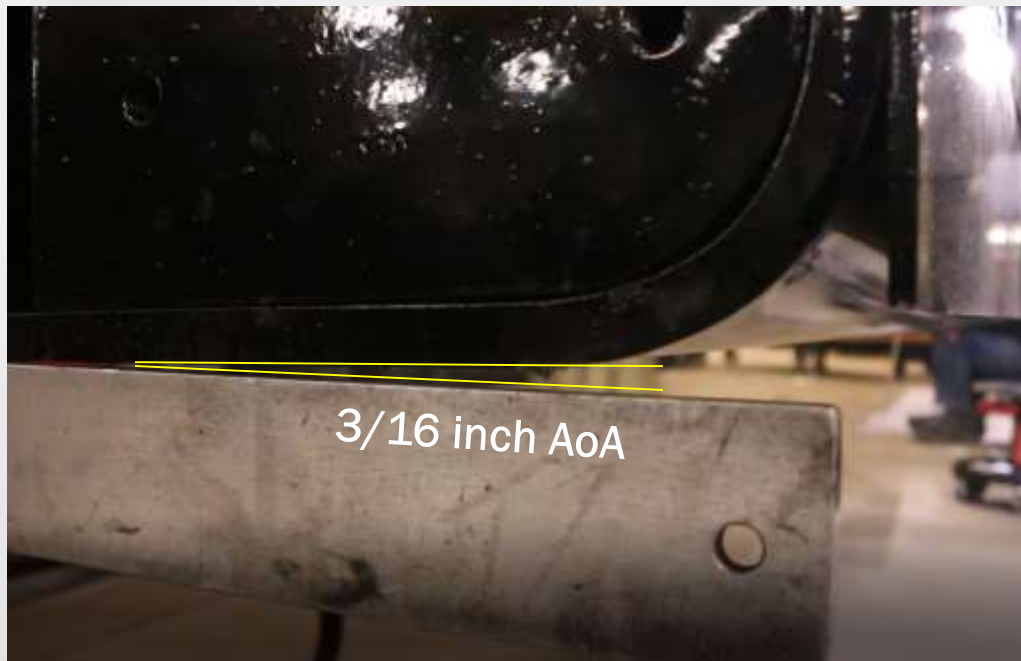

# VERTICAL OR MATCH HEIGHT

How do we know when the vertical height is off?

- Lines on the **inside** of main means the vertical is **too low**
- Lines on the **outside** of the main means the vertical is **too high**

The match height may need to be adjusted periodically depending on depth changes

The thinner the lift the higher the extension will need to ride

Once you are paving, if you see a line from the edge of the main screed then you will have to adjust the match height



# VERTICAL OR MATCH HEIGHT

If the material under the extension is lower than the main screed, the extension must be raised by adjusting.

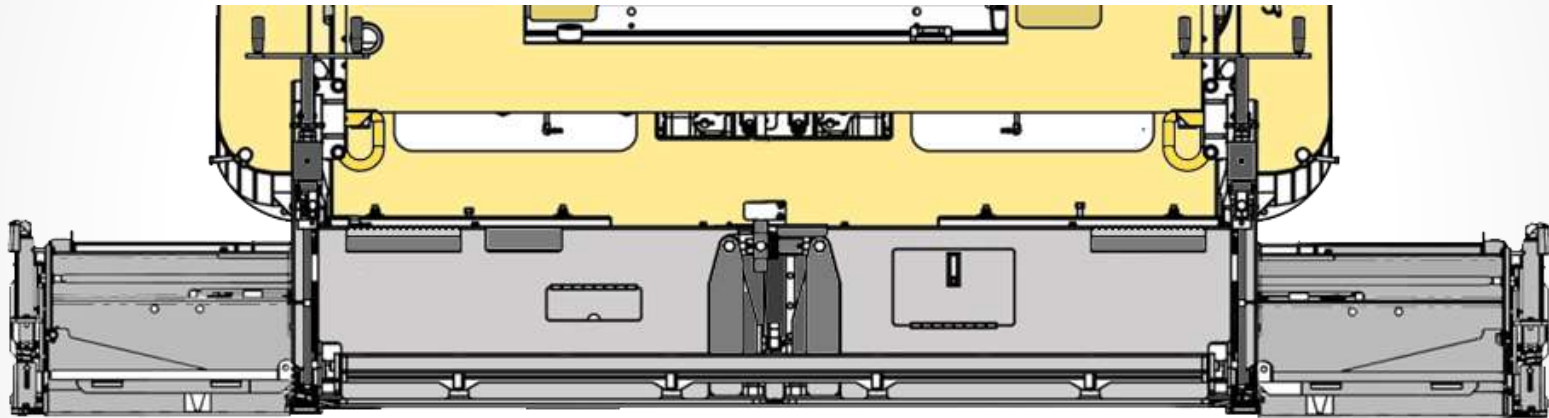

Extension  
Mat

Main Screed Mat

Extension  
Mat





# VERTICAL OR MATCH HEIGHT

If the material under the extension is higher than the main screed, the extension must be dropped by bumping the match height switch down.

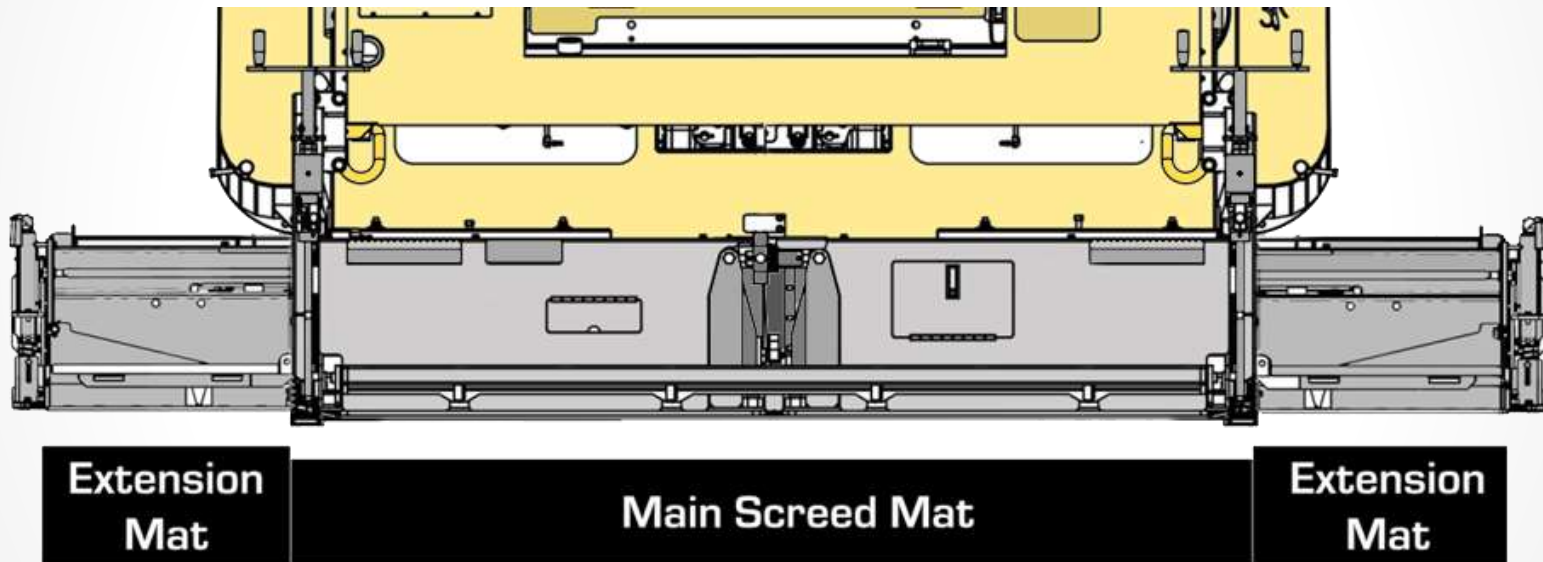

# MAT QUALITY AND TEXTURE

This mat (under extension) is too tight and shiny:

The angle of attack jack should be turned approx. one half revolution counter clockwise to push the bull nose down to decrease the mix feeding under the screed extension, thus transferring more weight to the main screed



# MAT QUALITY AND TEXTURE

By adjusting the extension to tighten the mat, you will notice changes in the texture.

Clockwise TIGHTENS the mat under the extension

Counter-clockwise LOOSENS the mat.



# PRESTRIKE-OFFS

The main strike off meters the flow of material under the screed  
Its adjustment directly affects the balance of the angle of attack  
1/2 inch above the screed bottom

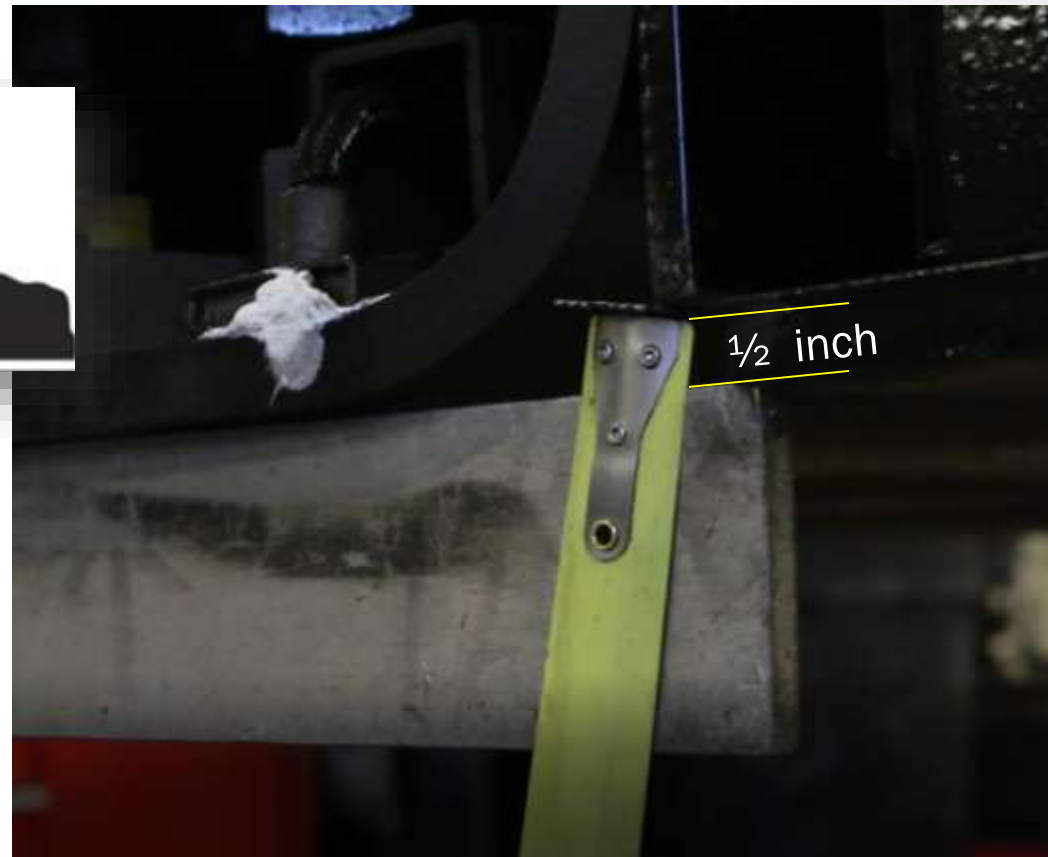
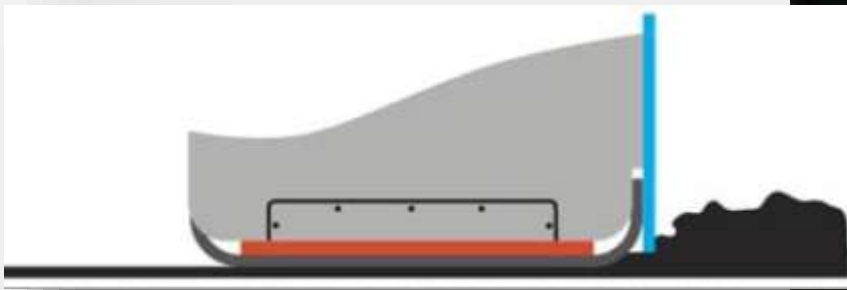

Remember, a strike-off adjusted too low will have the screed want to ride on the nose!





# MANAGING THE FEED SYSTEM

Feed sensor placement is one of the major problems in the field

When should I change my sensor position?

What benefit will I see from a different position?

The correct position will cure many problems with your paving operation.

Material that is not manageable will make a mat that is unmanageable.



# STARTING OFF AND PAVING

Producing a mat that has a consistent texture and density requires that all variables stay at a constant.

These variable are simple, and are:

1. Proper Angle of Attack (AoA)
2. Constant Paver Speed
3. Consistent Head of Material



# CLEAN UP AND JOINT PREP

If we just set down and start off without any prep, then the screed could dive.

Setting down and getting the following order will give us a successful start on takeoff:

- Allow for roll down
- Slow and consistent takeoff
- Take your time before adjusting
- Execute proper material control
- Check the joint with a straight edge.



# STARTING OFF

When starting off, it is necessary that the screed is correctly nulled and sufficient head of material present.

## Too Little Starting Material Or Incorrectly Nulled

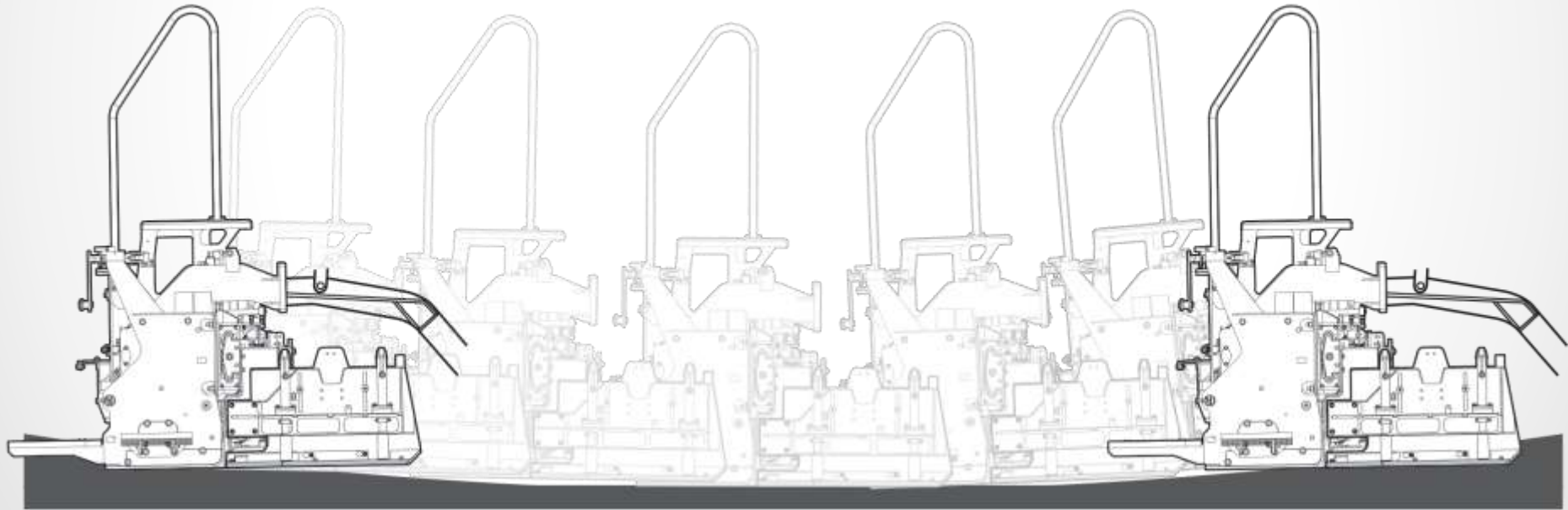

ASTEC INDUSTRIES, INC.





# STARTING OFF

When starting off, it is necessary that the screed is correctly nulled and sufficient head of material present.

## Too Much Starting Material

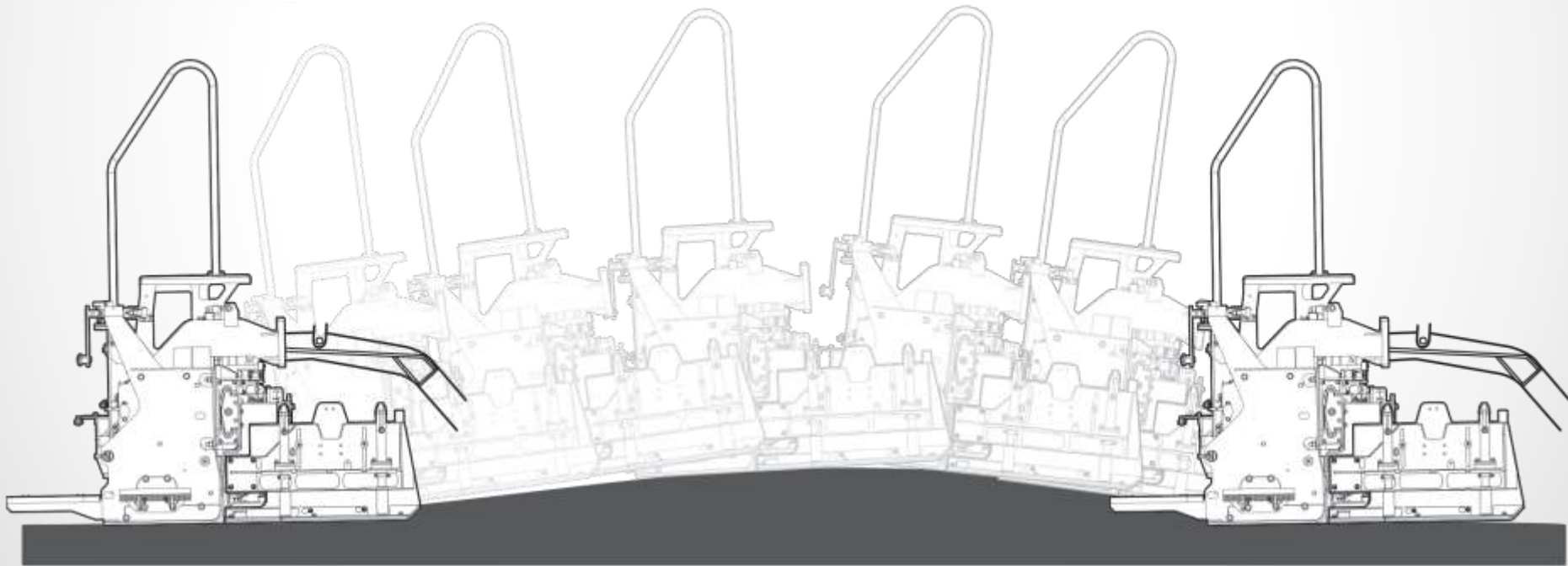

ASTEC INDUSTRIES, INC.



# STOPPING AND STARTING

It is recommended that you stop the paver as quickly as possible and accelerate as quickly as possible without being erratic.

This helps not only minimize mat deviations but also to maintain a constant, uniform head of material.

The only time you want to start paving slow is at the beginning of a job to make sure things get checked and are set correctly.



# JOINT PREPARATION

After compaction is complete, recheck the joint. Smoothness is critical!

Why start your job with possible penalties. Make sure you take the time to do it right the first time.



ASTEC INDUSTRIES, INC.



# JOINT MATCHING

As you lower the screed onto the shims as needed, check the endgate so that it is free to float up and down on the ground

Align the screed with the endgate overlapping  $\frac{1}{2}$  inch, no more than one inch on the existing joint

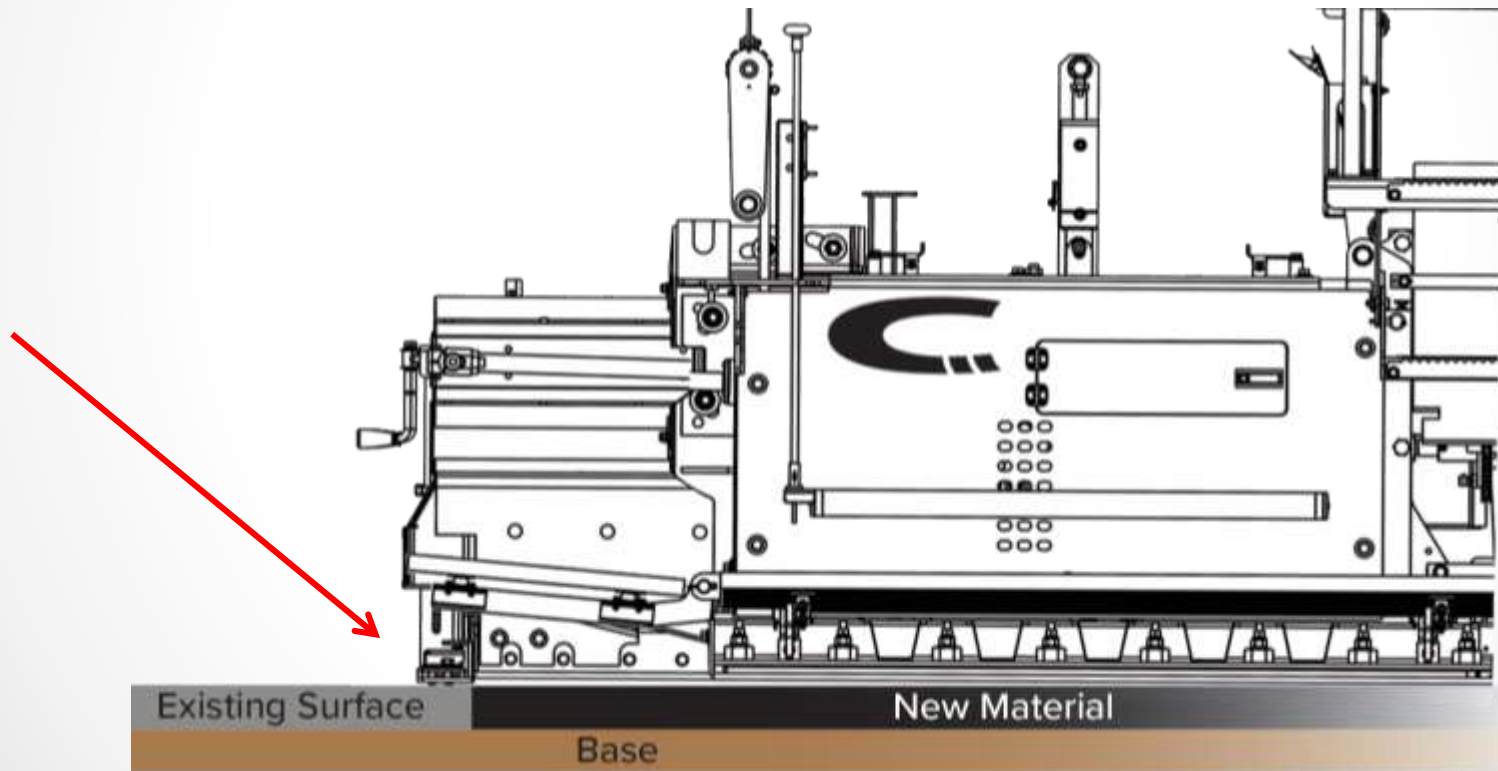



# JOINT MATCHING

Make sure the endgate is setting on the existing surface

The problem that most people have is not setting the endgates properly.

You should put just enough pressure to confine the material.

Existing Surface  
(Yellow Line)

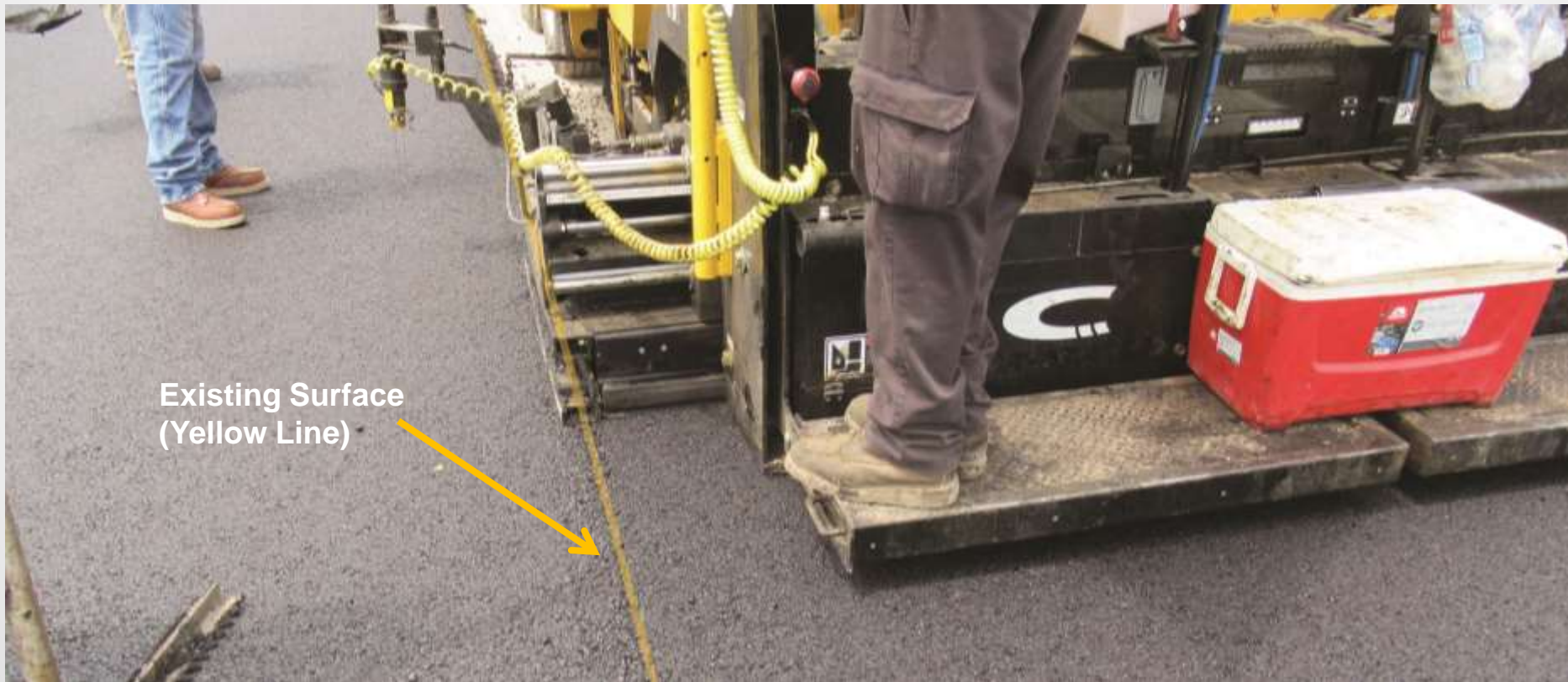

ASTEC INDUSTRIES, INC.



# STRONG JOINTS

Longitudinal joints are the weakest part of any mat. We can't all pave in echelon to eliminate the longitudinal joint, so proper matching is required

You can also achieve better longitudinal joint density by forcing more material into the joint through specialized attachments on the first and second pass.





# EFFICIENCY FOR BEST RESULTS



ASTEC INDUSTRIES, INC.



# JOB LAYOUT & PREP

You may lay a job out and it be just how you like it until the crew sees it.

If there is a way to make the job easier, then listen

In the end you may have to make fewer passes do the same job

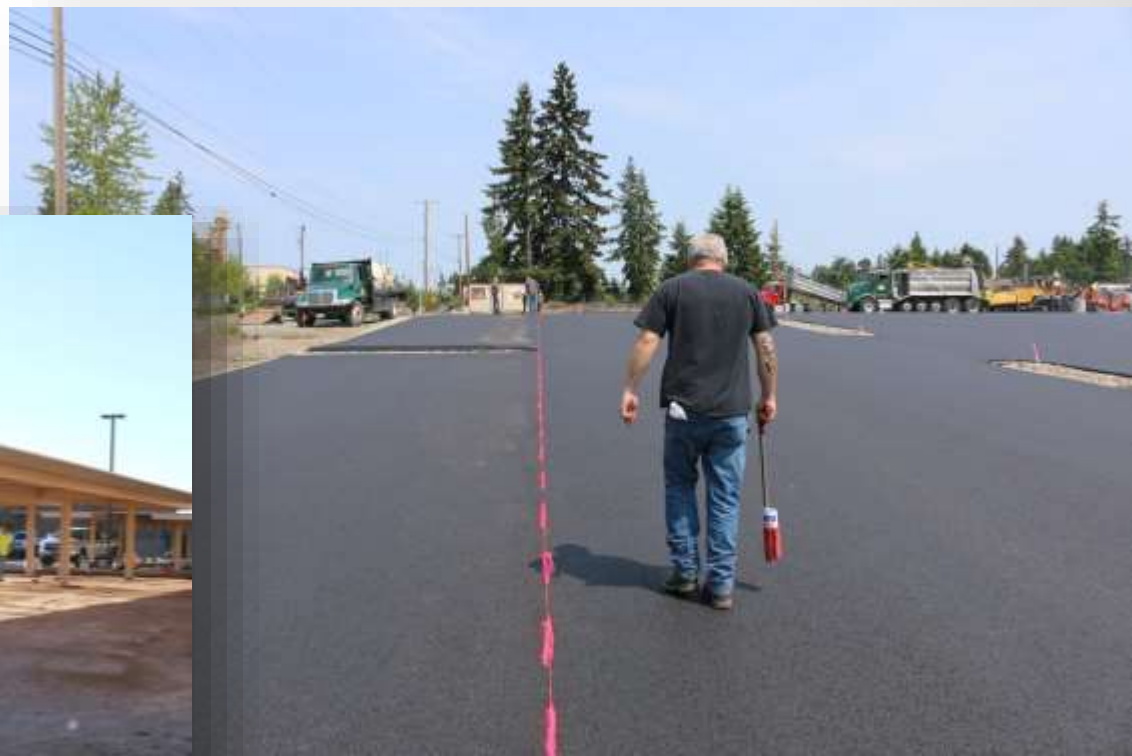

ASTEC INDUSTRIES, INC.





# 1 PASS OUT

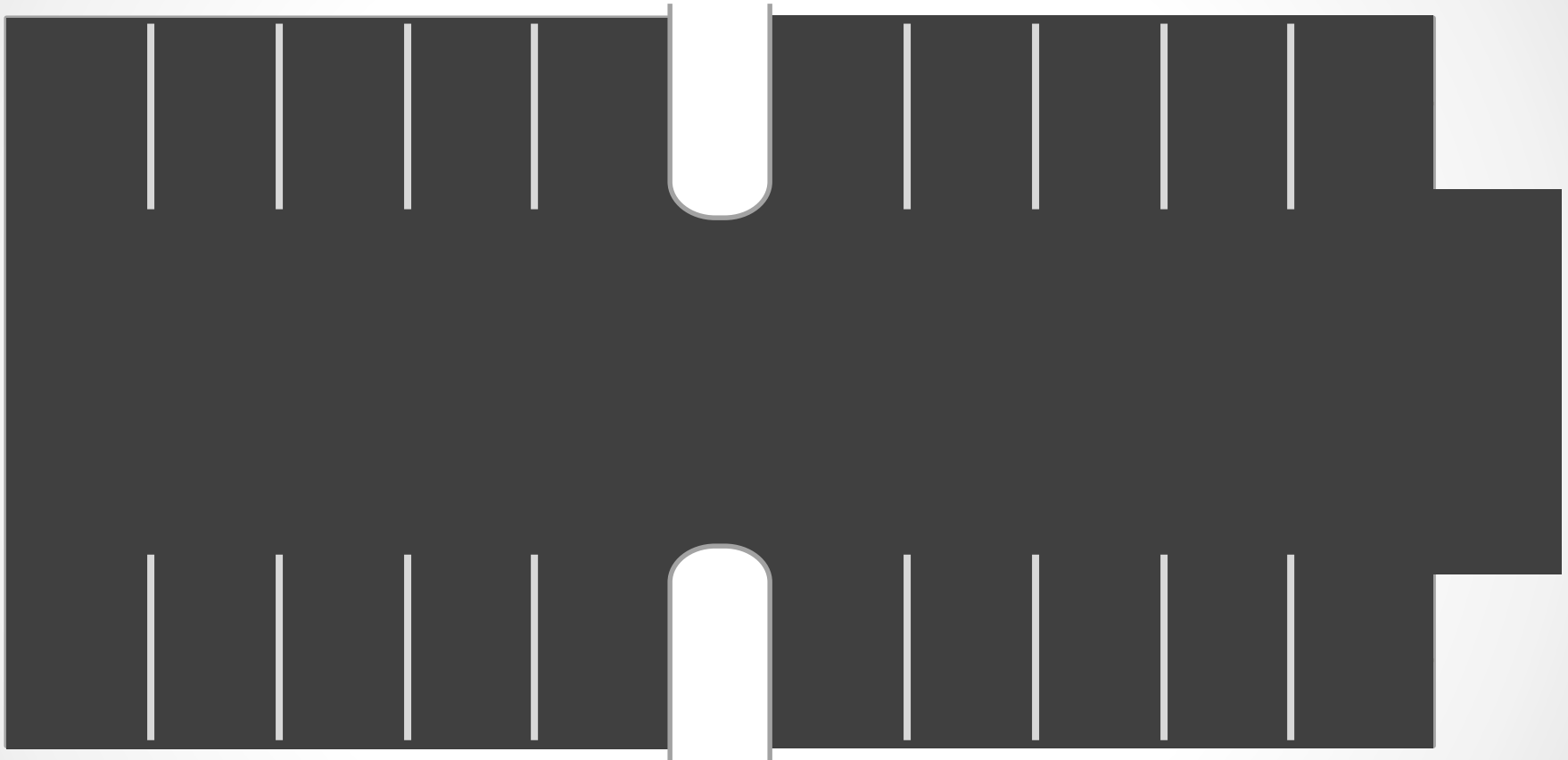

# 2 PASS OUT

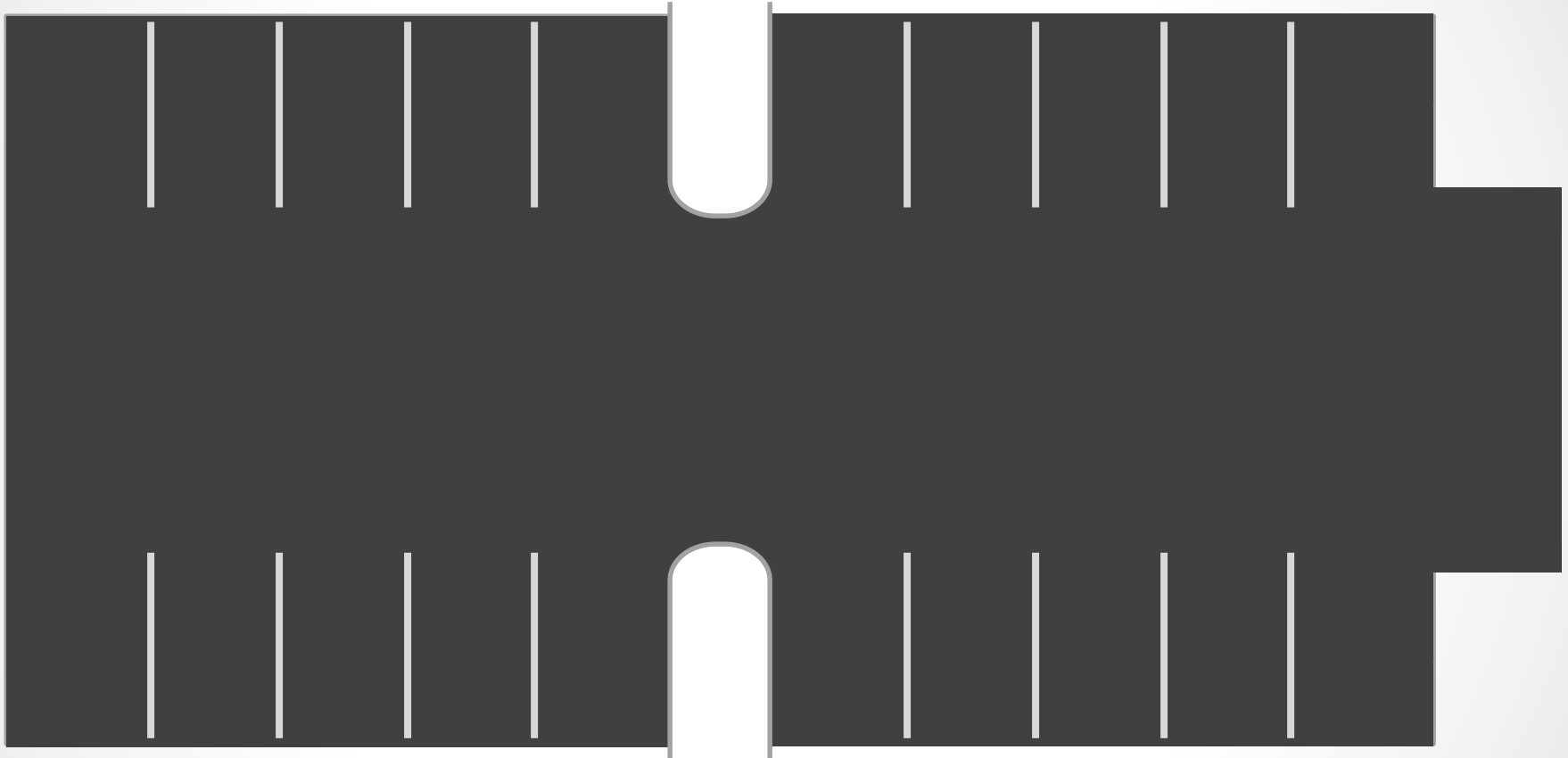

ASTEC INDUSTRIES, INC.



# OPEN PAVING

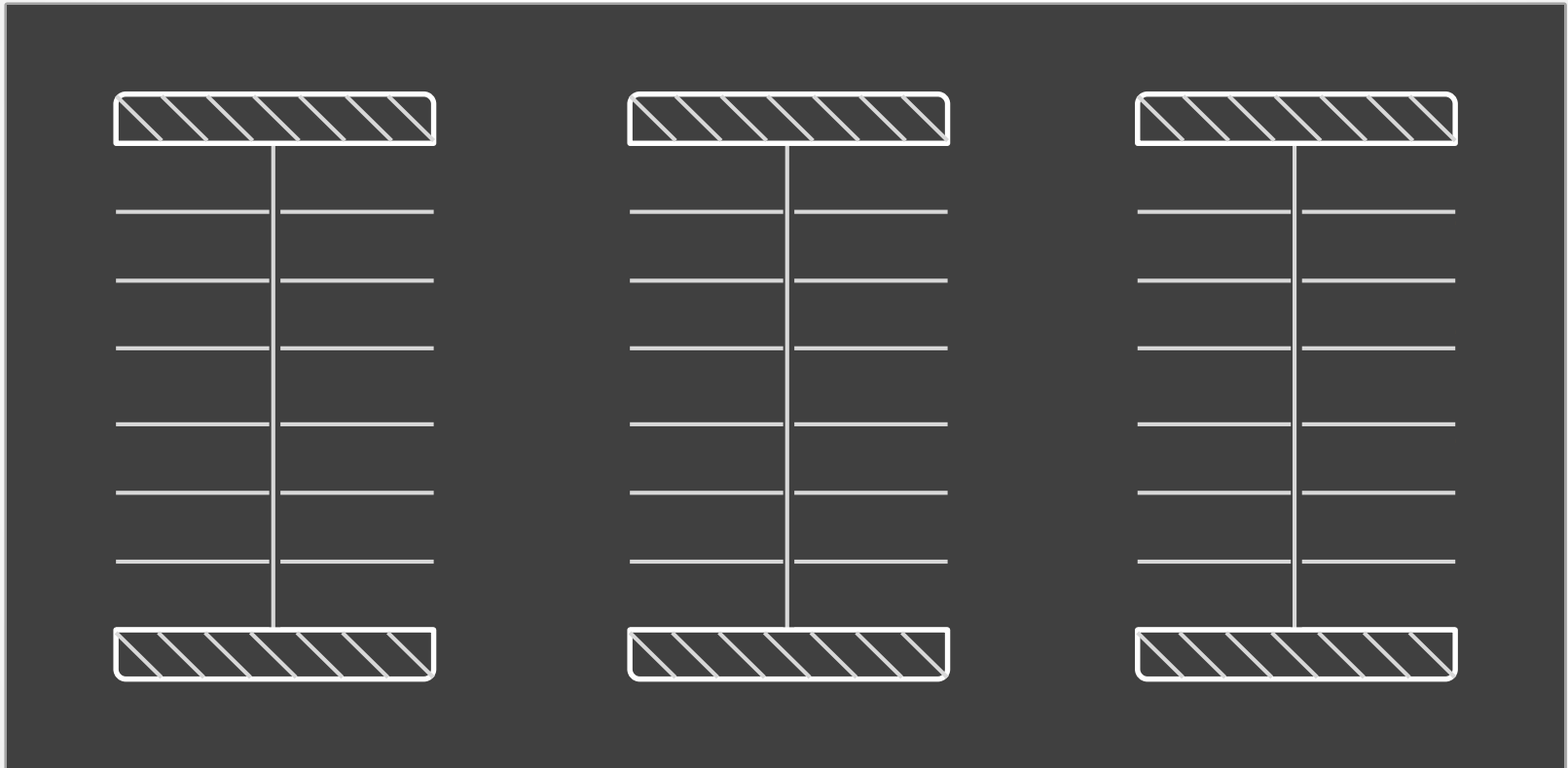

# POINTS TO REMEMBER

- Proper Pile Height
- Set Tow Points
- Set Angle of Attack (AoA)
- Set Flow Gates/Auger Cut Off Doors
- Set Auger Height
- Set Match Height
- Set PreStrike-Off
- Set Screed Flat with Lead Crown
- Set Endgates Properly
- Set Proper Overlap





# QUESTIONS?



ASTEC INDUSTRIES, INC.

